



**waag society**

*institute for art, science and technology*

# BioHack Academy Incubator Design





# Why we need an incubator

- The behaviour of microbes is temperature dependent
- Temperature dependent:
  - Enzyme reactions
  - DNA interactions
  - Cell state







# Industry standard

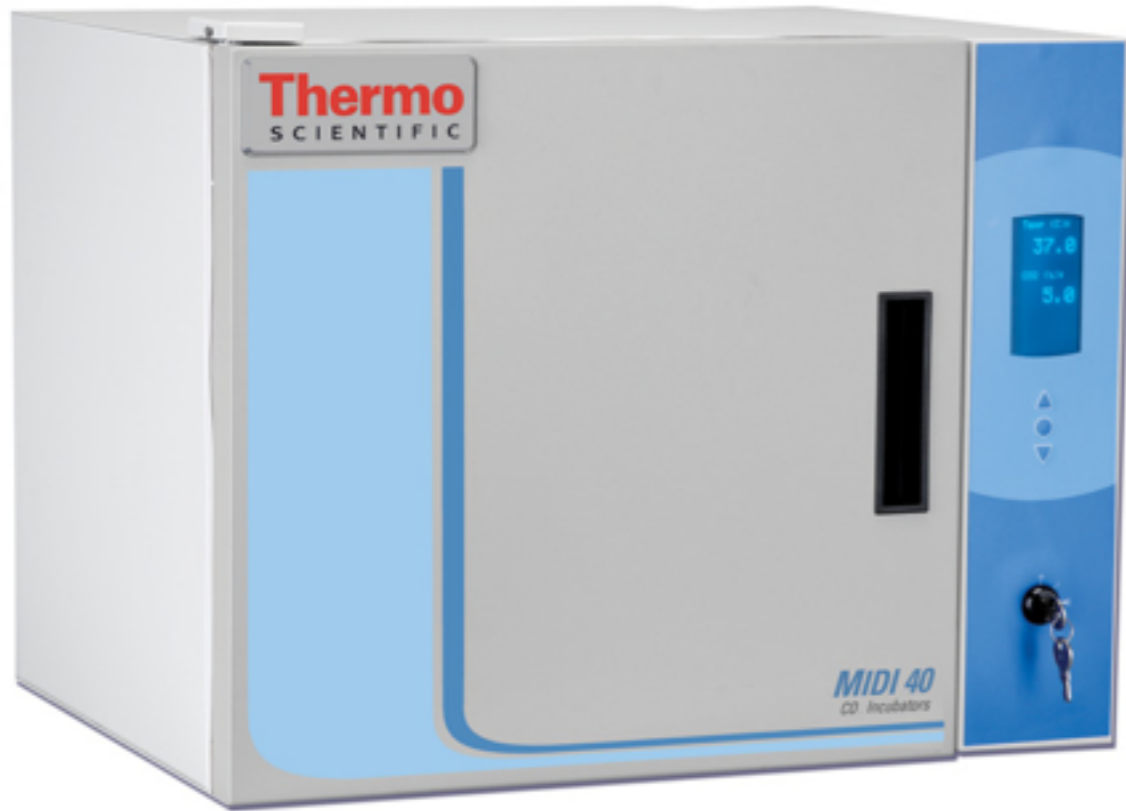



# Function

- Heat isolated enclosed cabinet, with see-through window
- Heat source
- Temperature controller
- Temperature indicator
- User interface to set temperature



## Design constraints:

- 9 cm petri dishes





# Biohack Academy Incubator

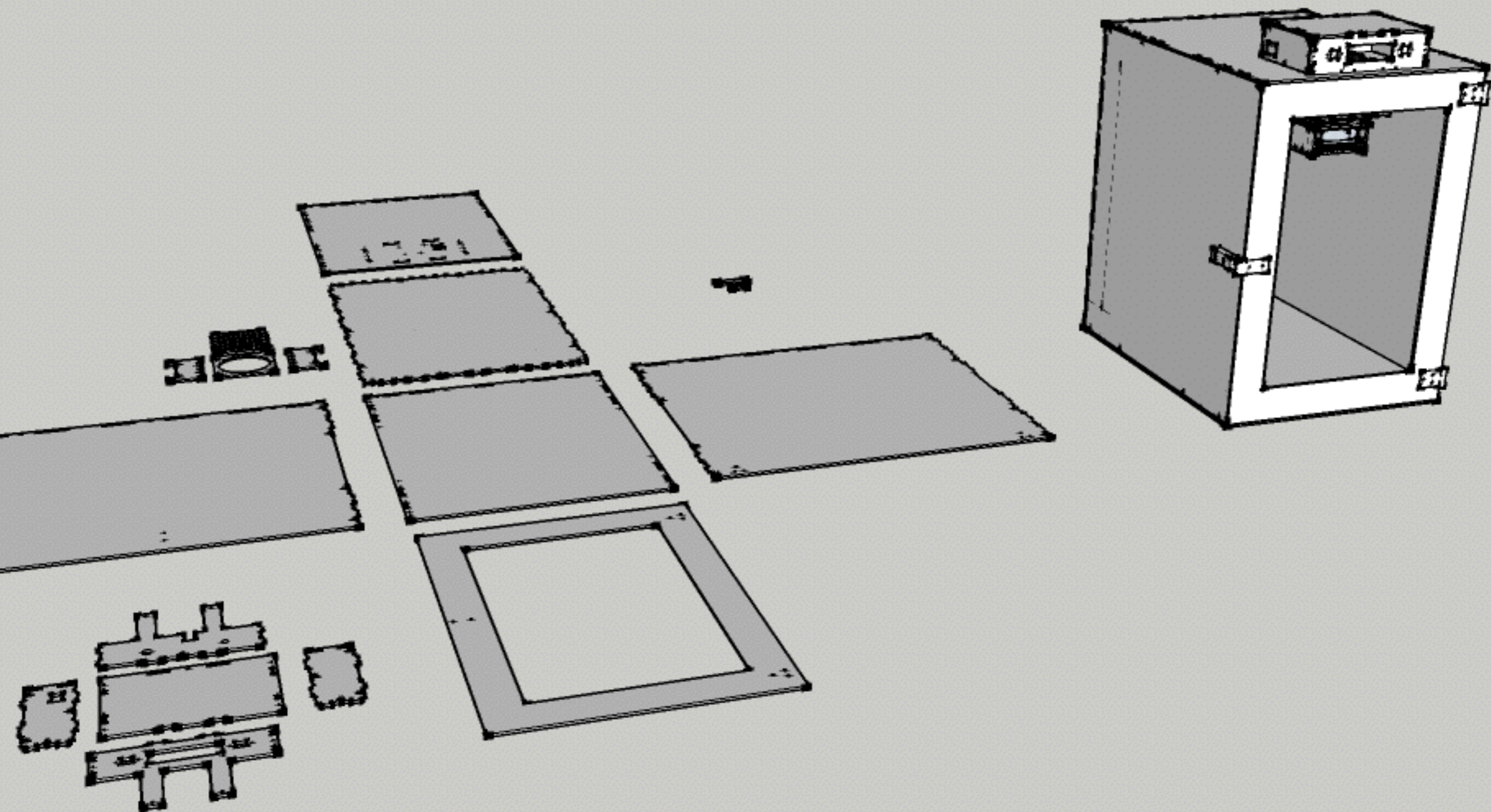





# BioHack Academy Incubator

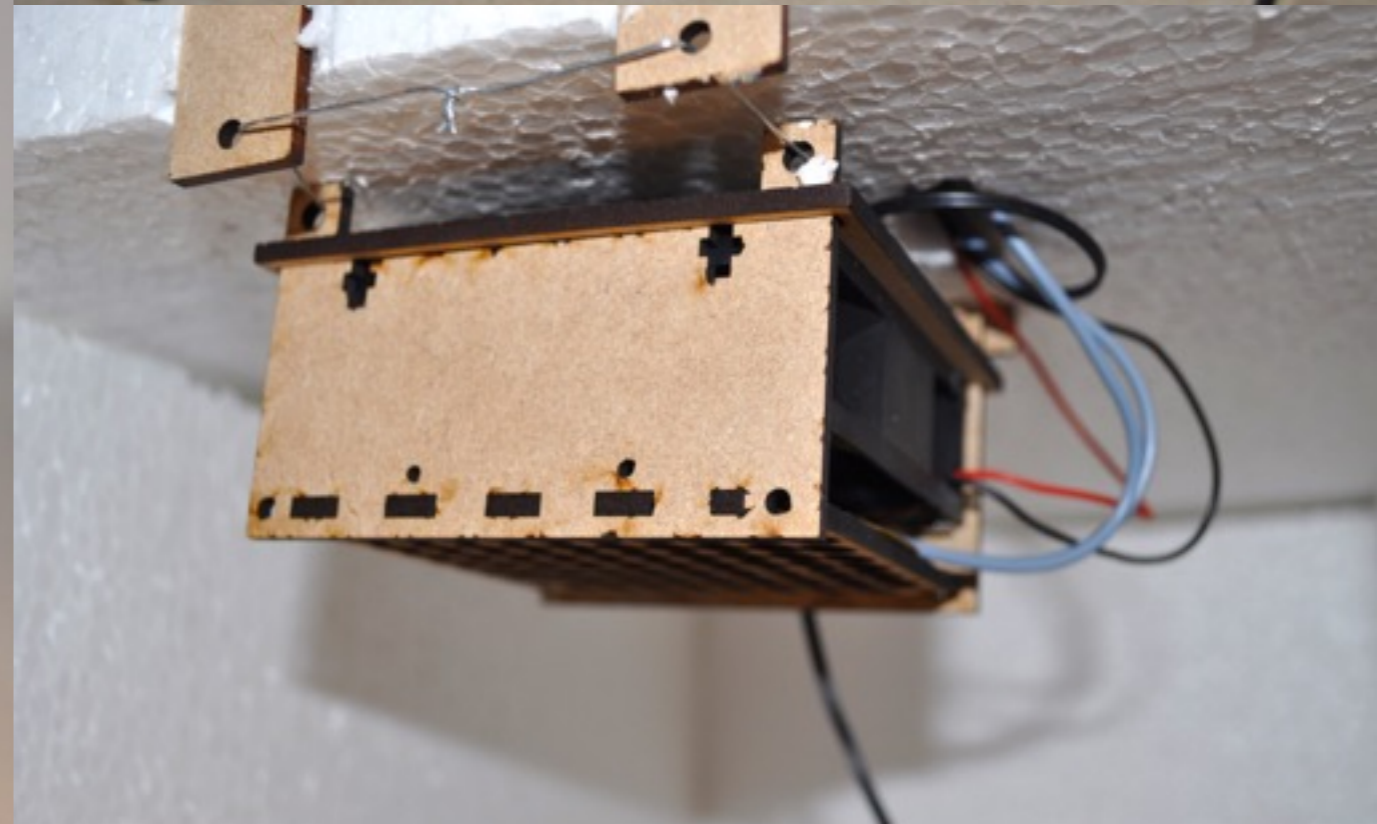
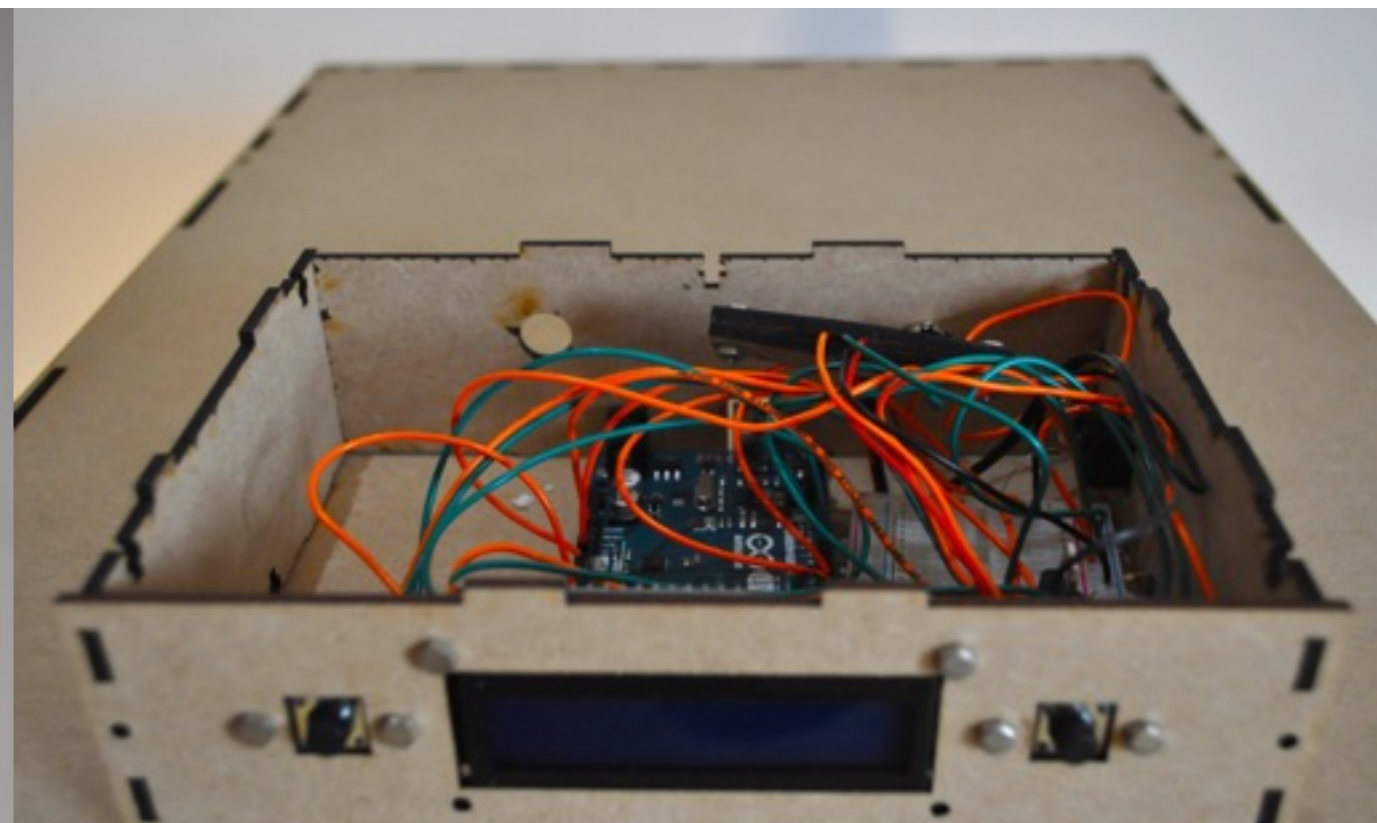
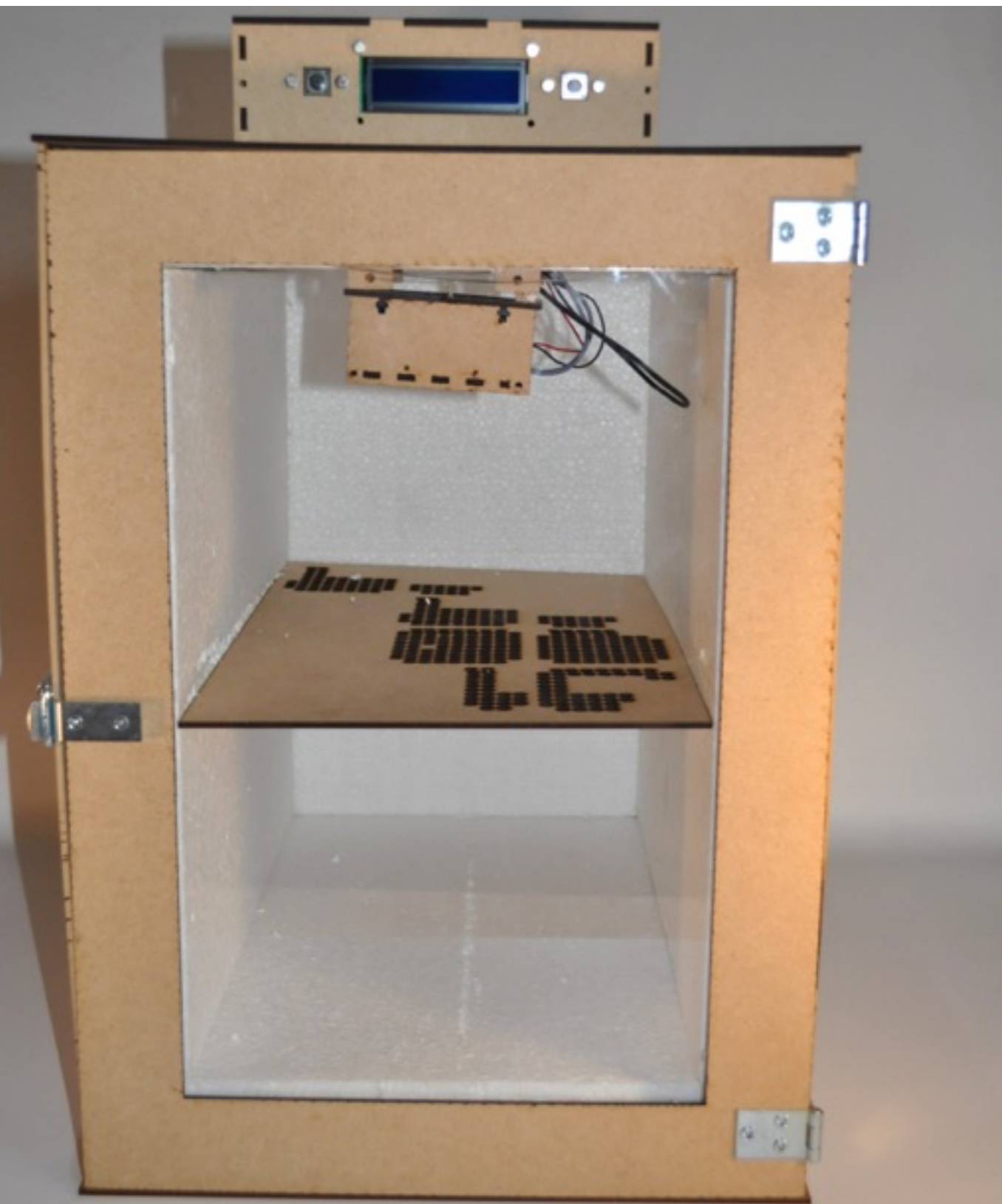





# Using the BioHack Board

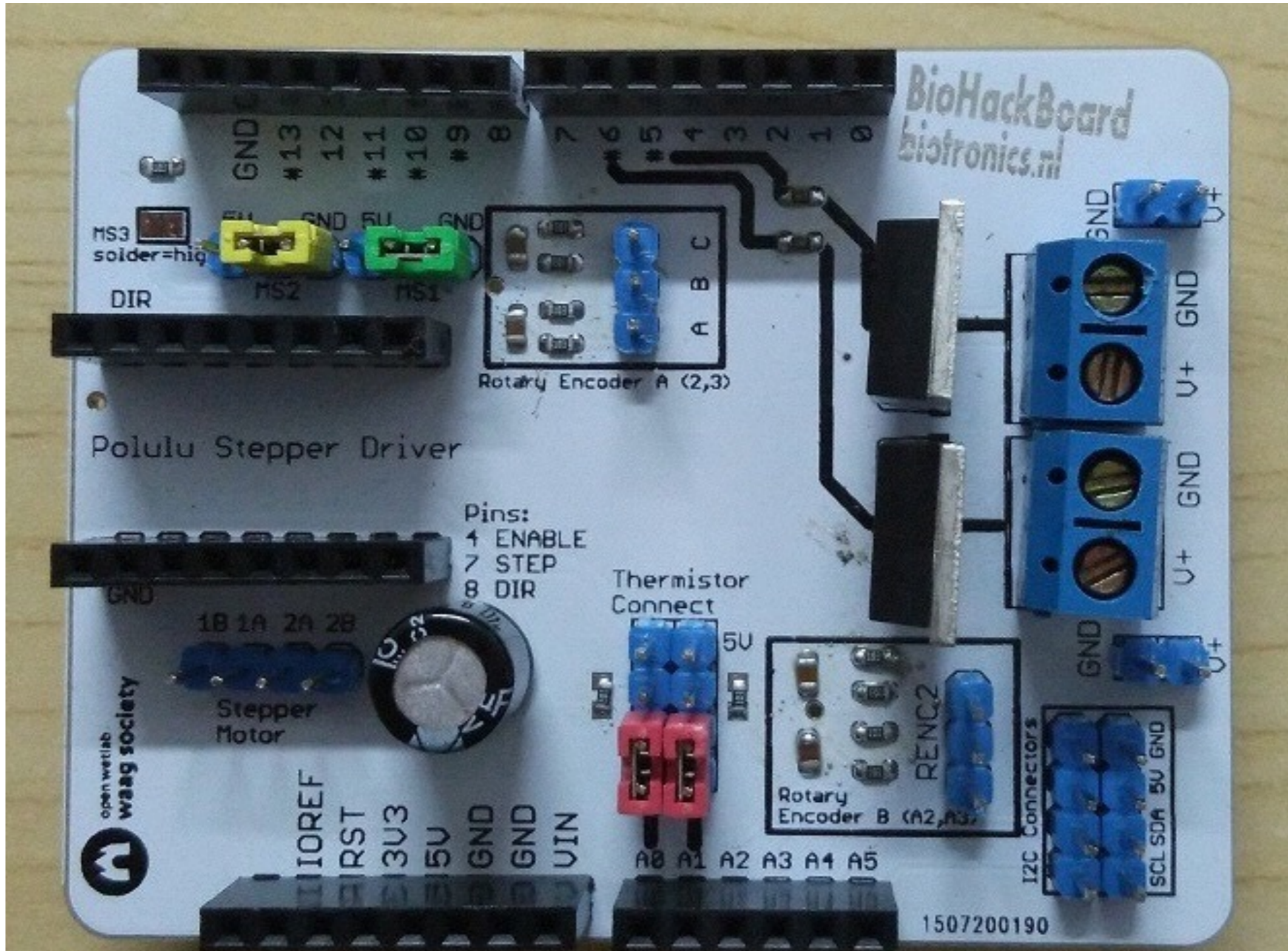





# Bill of Materials



= not necessary  
when using the BHA Board

No	Amount	Description	Supplier NL	Cost
1	4	3mm MDF 95 x 45 cm	Local wood store, like <a href="#">Houthandel Schmidt</a>	5.00
2	1	Expanded polystyrene (EPS)	<a href="#">Praxis</a>	7.99
3	1	3mm Acrylic sheet 27 x 41 cm	<a href="#">Plexiglas.nl</a>	3.50
4	1	12V 80 mm Axial Fan	<a href="#">EEO</a> , <a href="#">Farnell</a>	8.99
5	1	Power switch	<a href="#">iPrototype</a>	0.95
6	1	Water proof temperature sensor (*1)	<a href="#">HobbyElectronica</a> , <a href="#">iPrototype</a>	2.95
7	1	I2C LCD display	<a href="#">iPrototype</a> , ( <a href="#">HobbyElectronica</a> + <a href="#">HobbyElectronica</a> )	16.95
8	2	MOSFET	<a href="#">Farnell</a> , <a href="#">EEO</a>	0.98
9	4	10K resistor	<a href="#">Farnell</a> , <a href="#">EEO</a>	0.06
10	1	Diode	<a href="#">iPrototype</a> , <a href="#">EEO</a>	0.19
11	2	Button	<a href="#">iPrototype</a>	0.55
12	1	White LED	<a href="#">iPrototype</a> , <a href="#">EEO</a>	0.52
13	1	220 Ohm resistor	<a href="#">iPrototype</a> , <a href="#">EEO</a>	0.45
14	1	7.5 W power supply	<a href="#">iPrototype</a> , <a href="#">EEO</a>	13.95
15	1	Jack Adapter	<a href="#">EEO</a>	0.85
16	1	Heating foil	<a href="#">Conrad</a>	20.68



# Powering an LED







# LED circuit

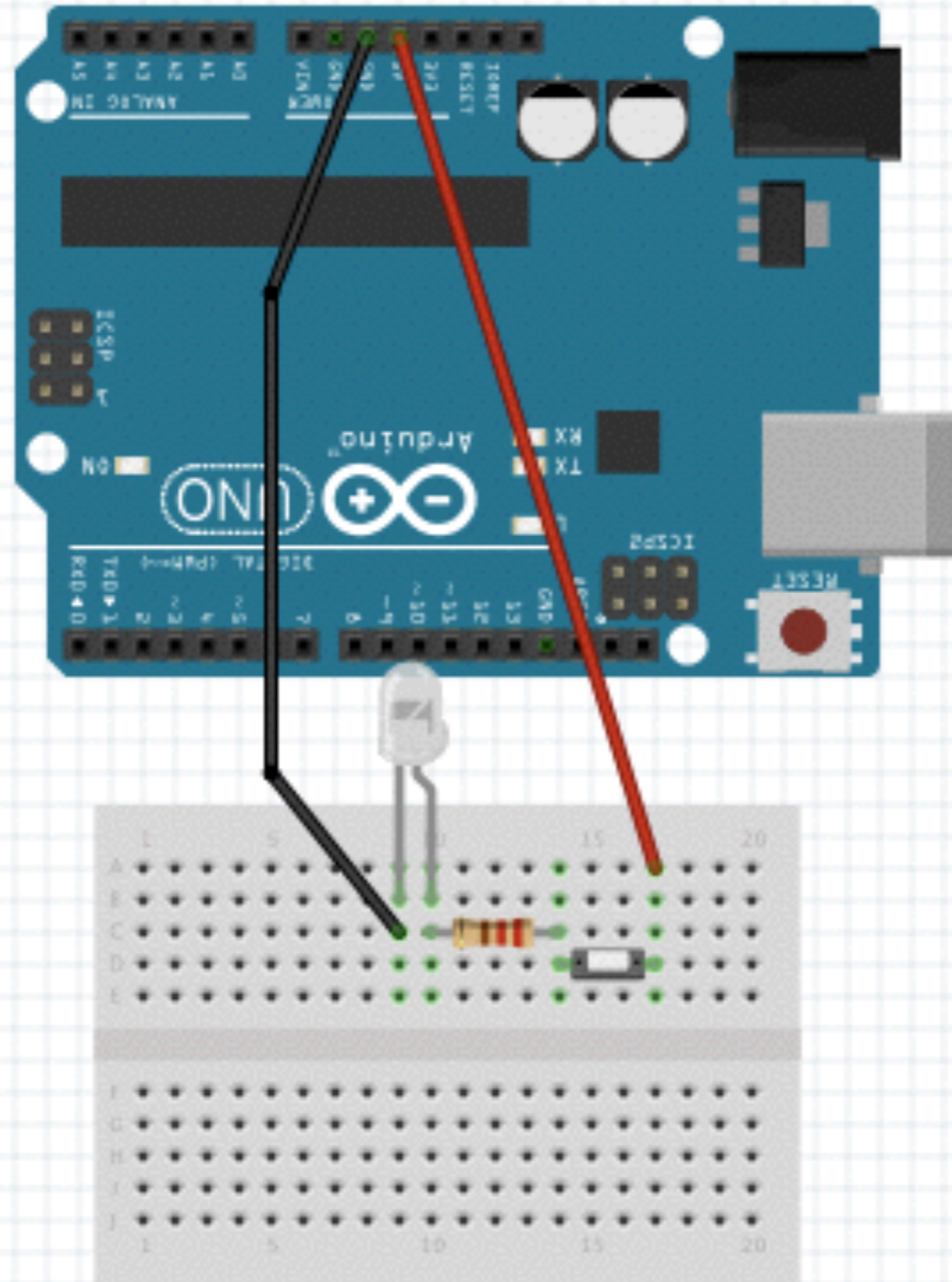



## Sensing the temperature

- 10K thermistor







# Sensing the temperature

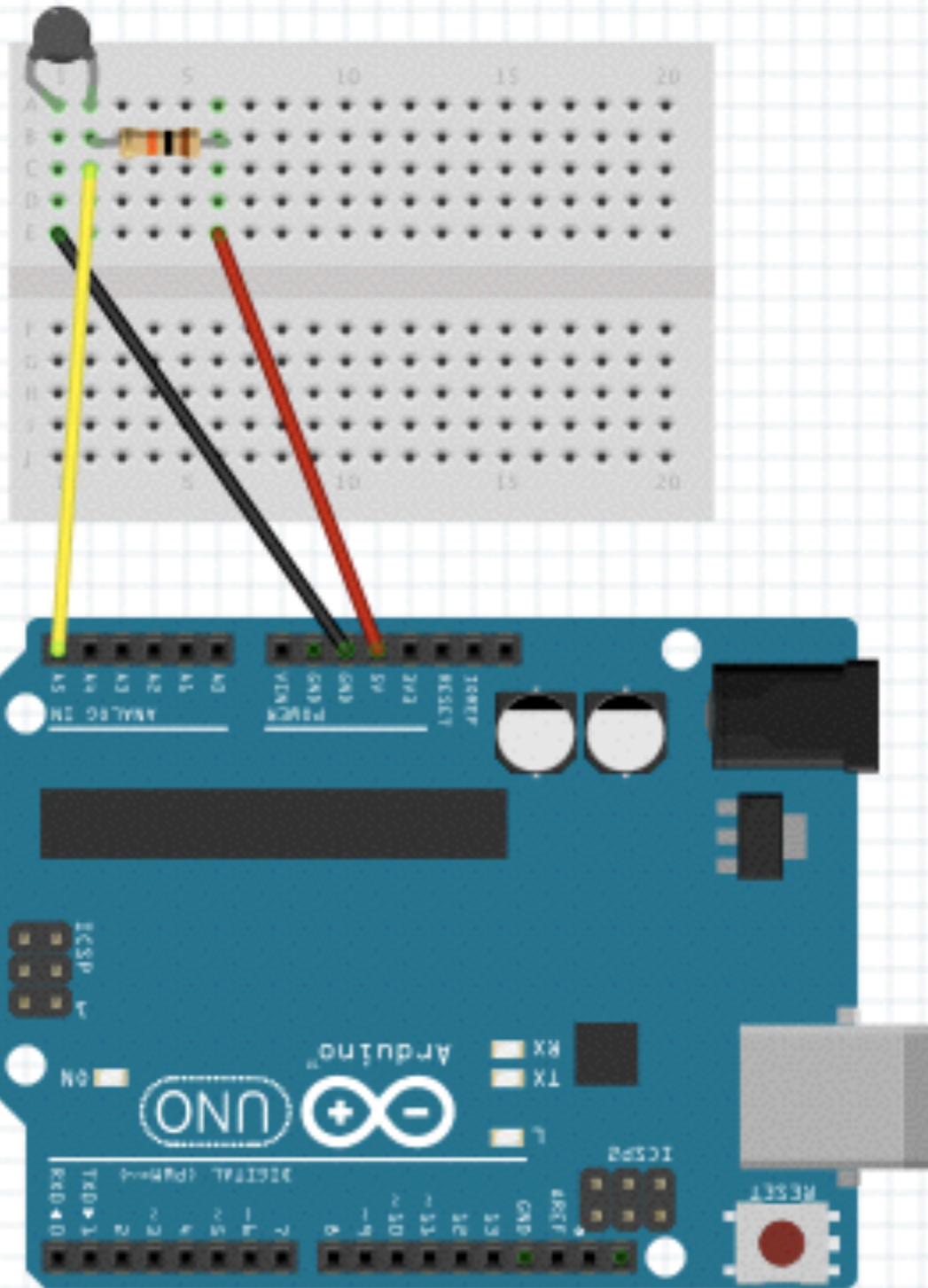



# Schematic

$$V_{out} = V_{in} \left( \frac{R_2}{R_1 + R_2} \right)$$

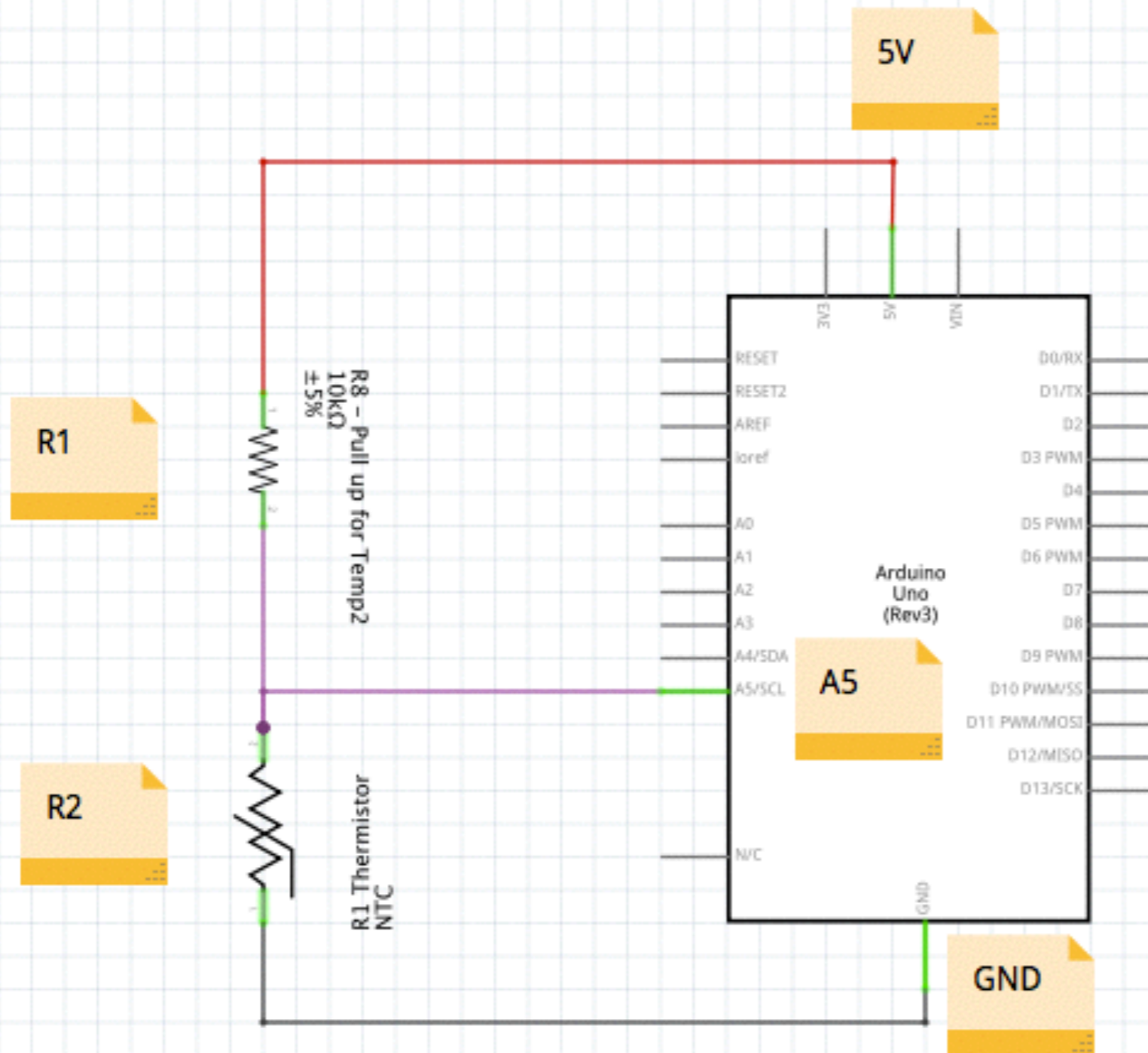





## Push buttons

## Pull down resistors

- 10 K Ohm

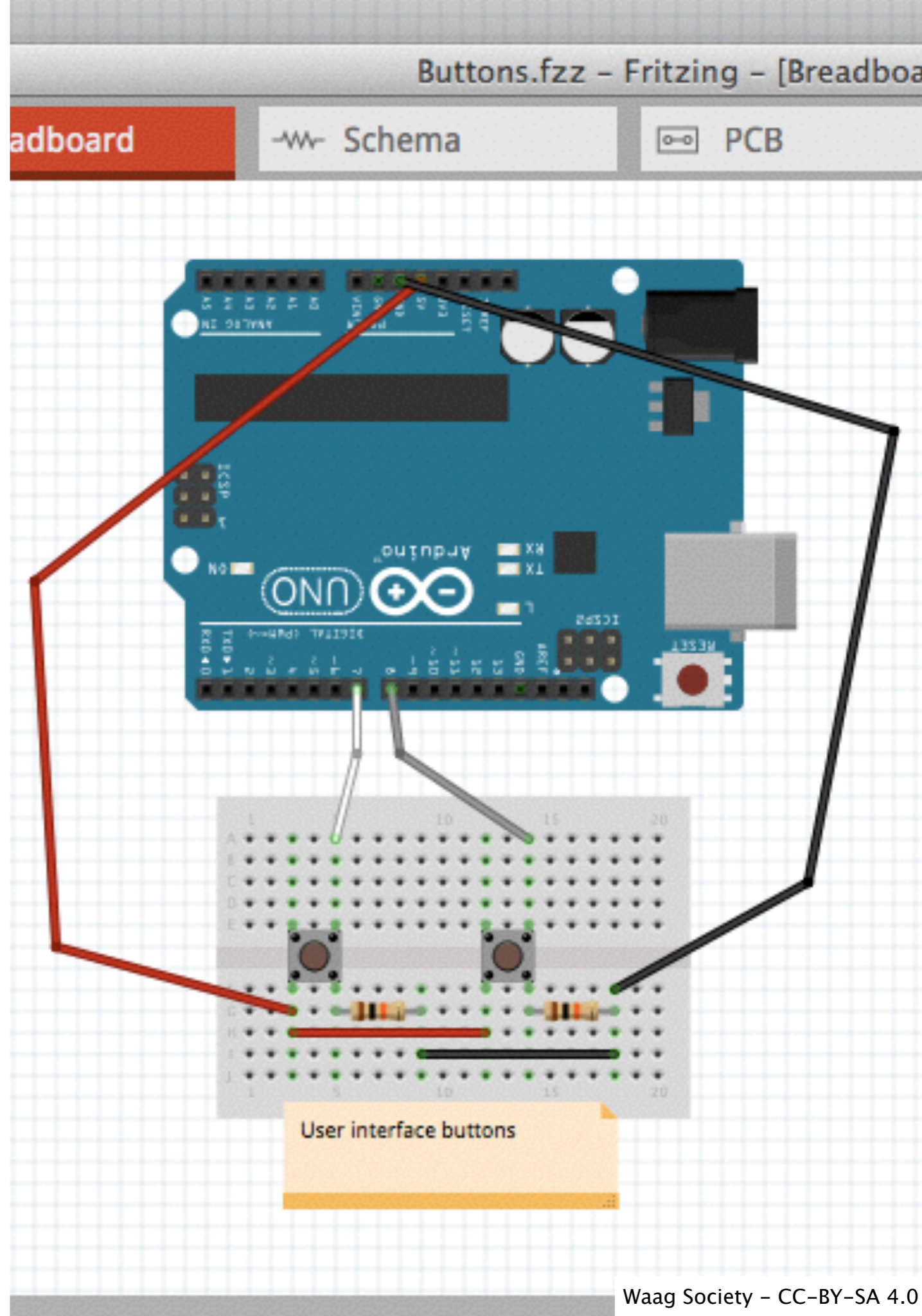



# Selecting a heat source

- Lamp
  - Heat as a by product
- Microwave
  - Needs liquid to heat
- Infrared
  - 100W infrared
- Power resistor





# Fan speed controller

- MOSFET
  - Semiconductor
- N-channel
- 60V
- 30A

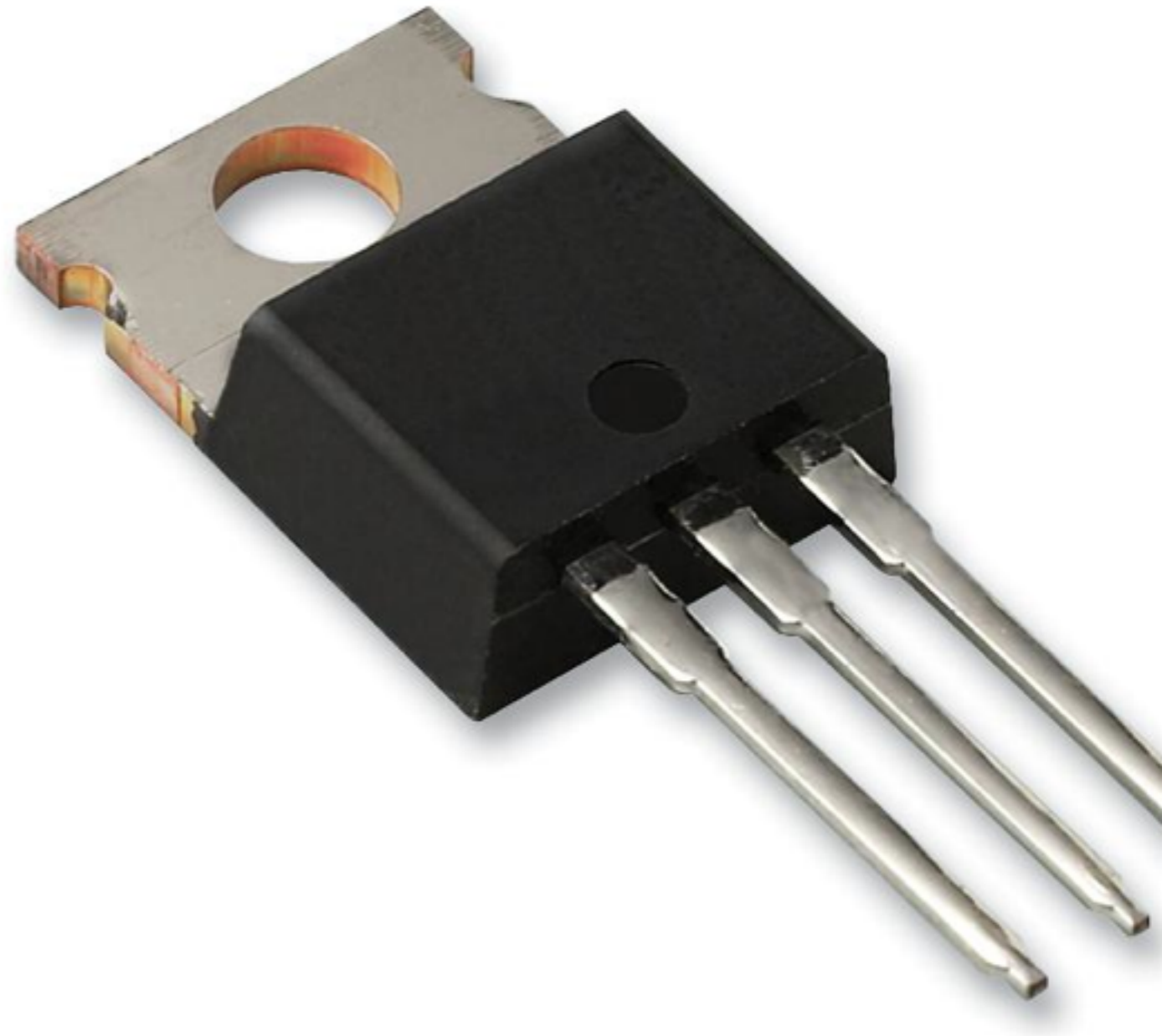





# Controlling the fan

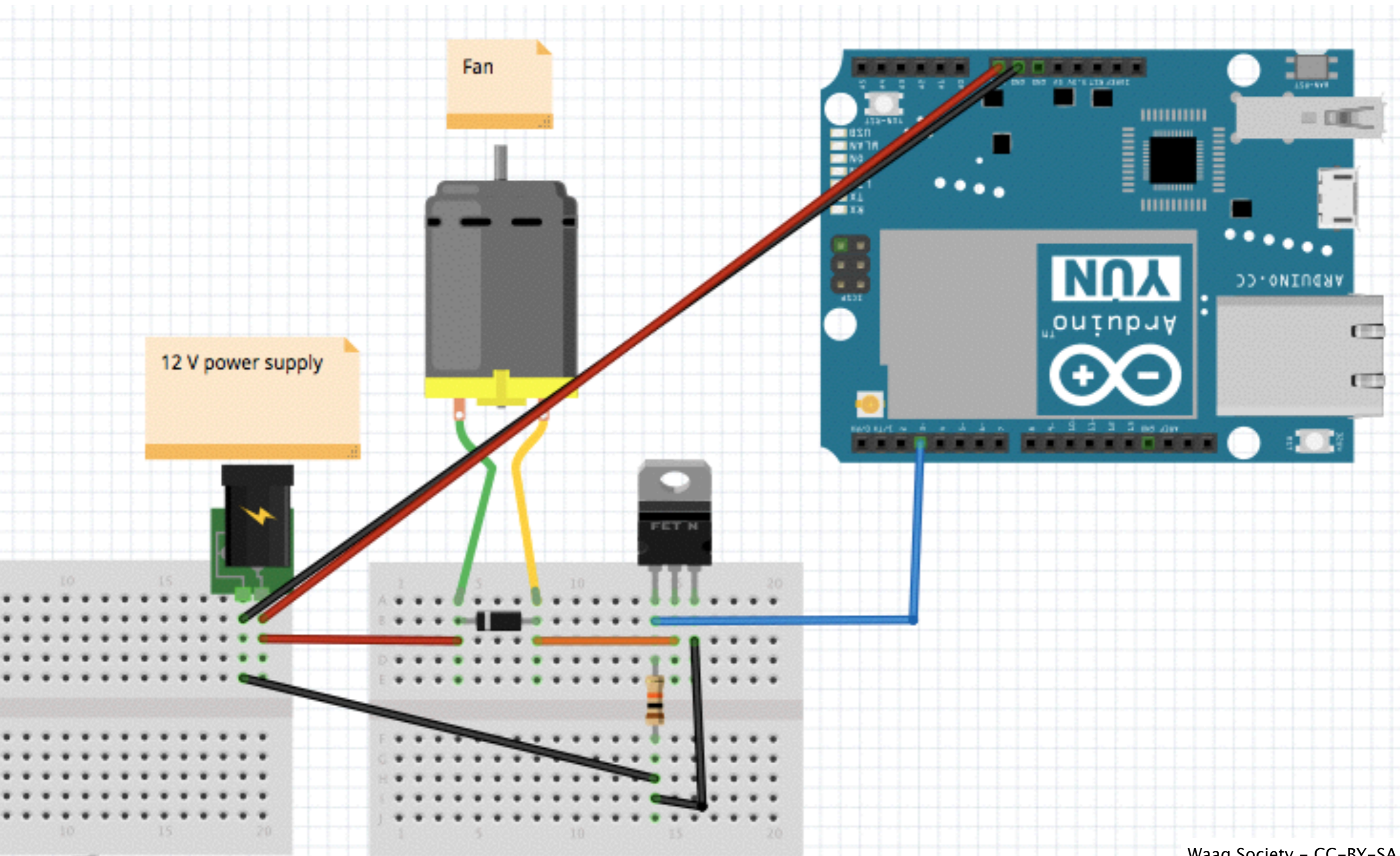



# All of the electronics together

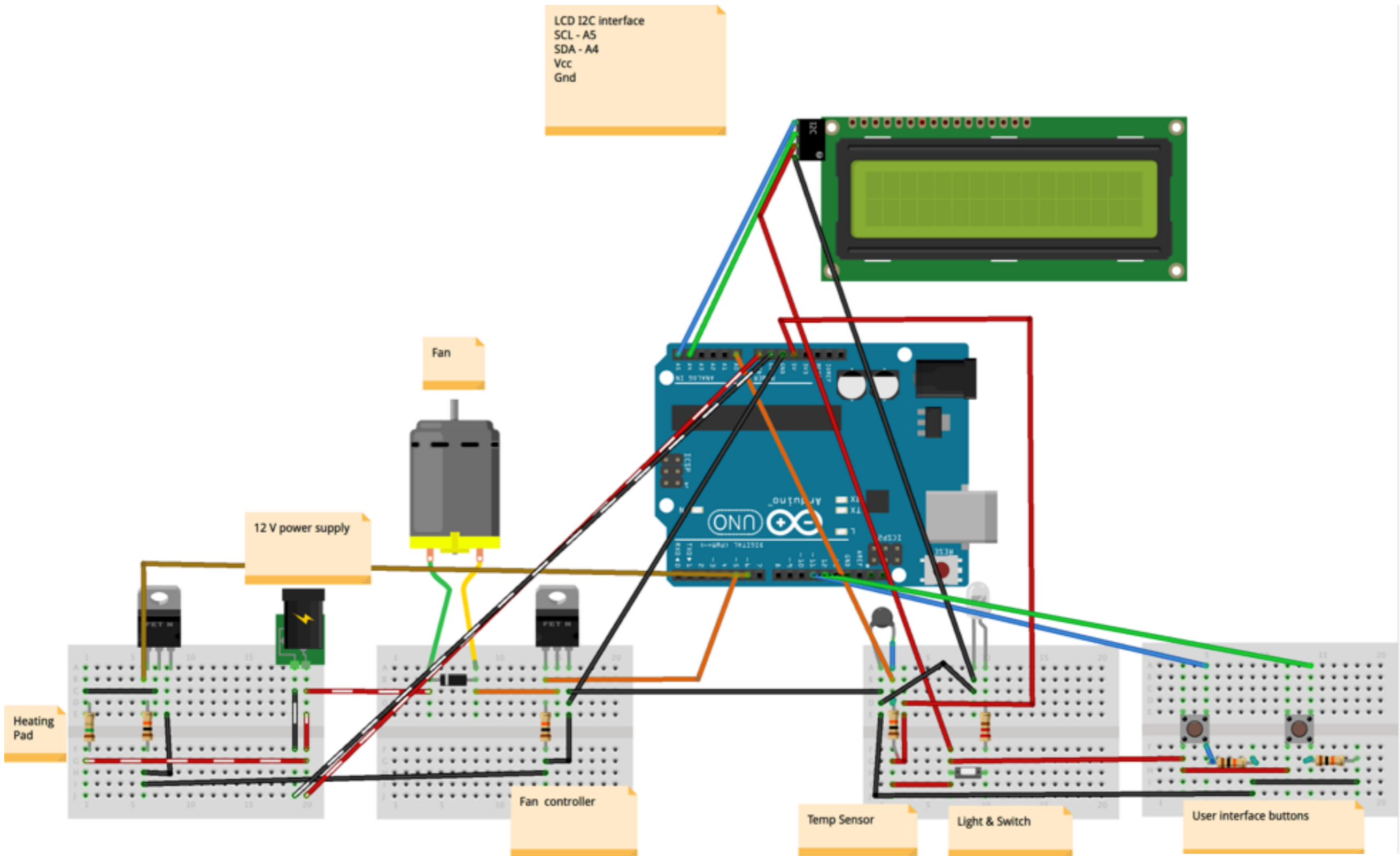



# Schematic

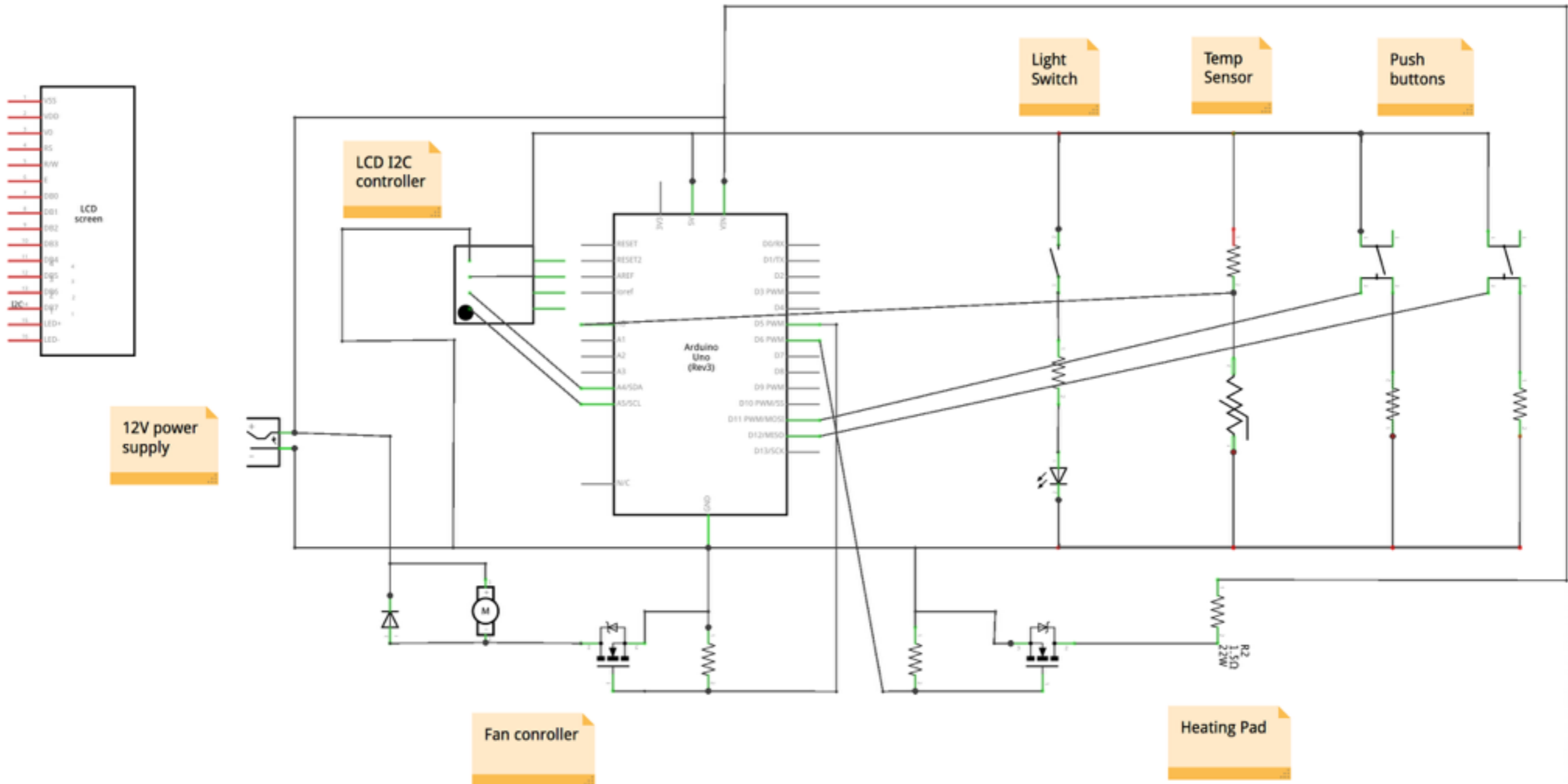





# Power Supply

$$P = A \times I$$

*Power = Current  $\times$  Potential*

*Watt = Ampere  $\times$  Volt*

- 1 x 30 mA LEDs
- 1 x 250 mA Arduino
- 1 x 400 mA Fan
- 1 x 30 mA 7 segment display
- 1 x 430 mA heating pad
  
- Total: 1140 mA
- So a 1.5 Amp power supply should be enough





# Arduino tutorial codes

- MOSFET code:
  - <http://bildr.org/2012/03/rfp30n06le-arduino/>
- Button code:
  - <http://arduino.cc/en/tutorial/button>
- Thermistor code:
  - <http://computers.tutsplus.com/tutorials/how-to-read-temperatures-with-arduino--mac-53714>



# Code



This repository Search

Pull requests Issues Gist



BioHackAcademy / BHA\_Incubator

Unwatch 4 Star 4 Fork 5

Code Issues 0 Pull requests 0 Wiki Pulse Graphs Settings

Branch: master BHA\_Incubator / Arduino Code / Incubator /

New file Upload files Find file History

<input type="checkbox"/>	PieterVanBoheemen updating pins	Latest commit eaaeff4 22 days ago
	..	
<input type="checkbox"/>	Incubator.ino	updating pins 22 days ago
<input type="checkbox"/>	LiquidCrystal_I2C.cpp	bha3 a month ago
<input type="checkbox"/>	LiquidCrystal_I2C.h	bha3 a month ago







# Code logic

- Measure temperature
  - Turn lamp on when temperature is lower than target
  - Turn lamp off when temperature is higher than target
- Check whether a button is pushed
  - If left button is pushed increase target temperature
  - If right button is pushed decrease target temperature
- Display current temperature
  - In case left or right button is pushed, display target temperature for 5 seconds



# Nice to haves

- PID control
- Magnetic door lock
- Lever switch that checks whether door is locked
- Sound alarm in case door is open for too long
- Webcam inside



# PID control

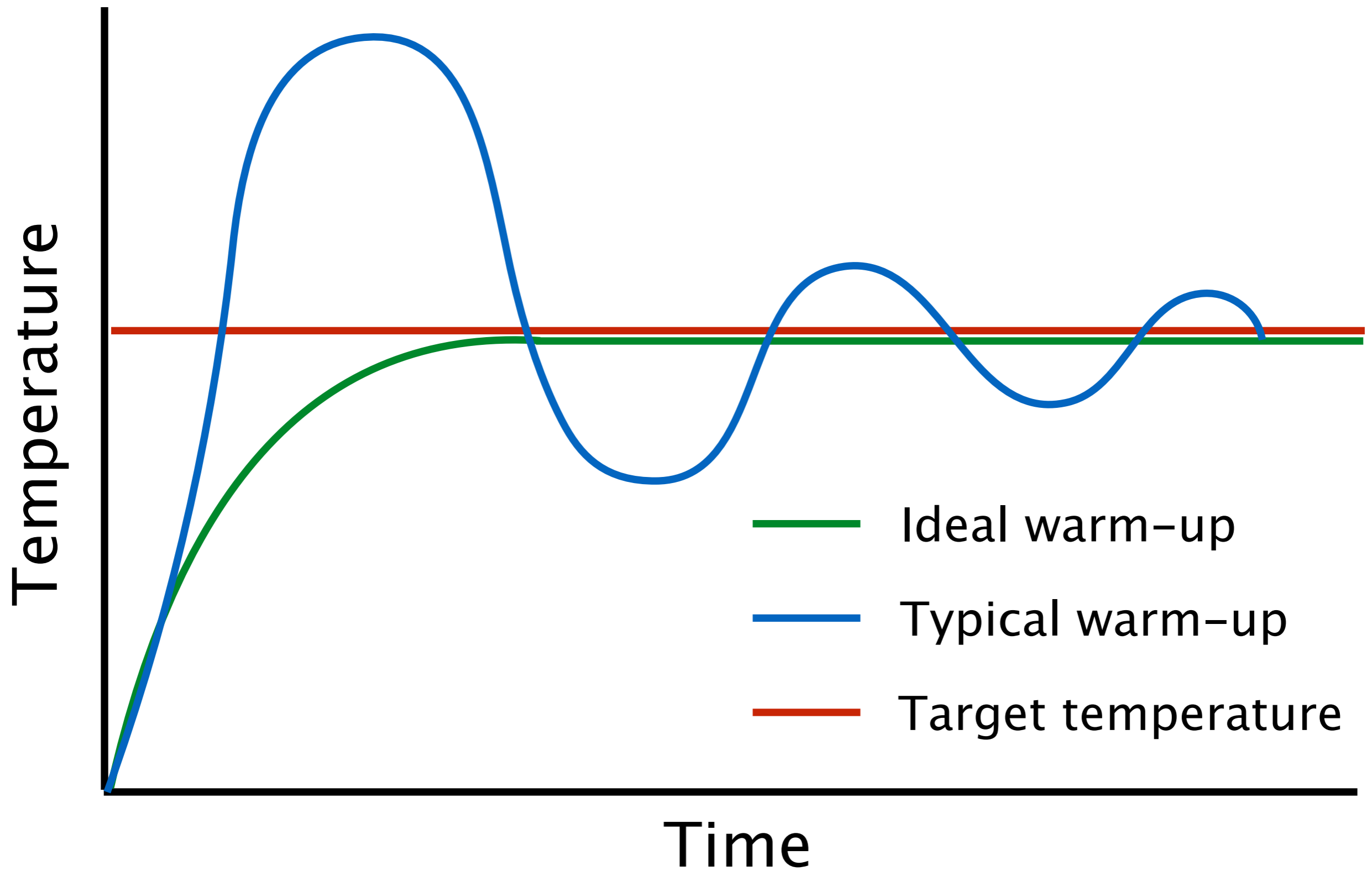





**some**

**rights**

**reserved**